

# **Beginners Agility Program Guidelines**



**October 1, 2011**

**North American Dog Agility Council**  
P.O. Box 1206  
Colbert, OK 74730  
[www.NADAC.com](http://www.NADAC.com)

# **NADAC Beginners Agility Program**

## **Purpose of Beginners Agility Tests**

The purpose of a NADAC Beginners Agility Test is to demonstrate the ability of the dog and its handler to perform many of the basic tests to prepare them for a future agility career. The dog should be under control at all times and show a willingness to work with the handler. Handlers should always conduct themselves in a sportsmanlike fashion.

## **Eligibility for Entry**

All healthy, trained dogs over twelve (12) months of age are eligible to compete in NADAC Beginners Agility test. There is no leeway in the dog's age, even by one day; the dog **MUST** be a minimum of twelve months old on the day of the test in which the dog is to compete.

Dogs must be registered with NADAC prior to competing in a NADAC Beginners Agility test.

Bitches in heat, lame, or blind dogs are ineligible for entry, as is any dog with a deformity that may cause a judge to not be able to reasonably assess the dog's ability to function and perform agility obstacles safely, and in a manner that is in the best interest, health and welfare of the dog.

Any dog that demonstrates aggression towards any person or any dog, whether inside or outside the ring, must be excused from the Beginners Agility test.

Any dog that the tester feels is not in enough control to perform all obstacles in a safe manner will be excused from the test.

All NADAC Beginners Agility tests shall be open to purebred and mixed breed dogs.

## **Beginners Agility Testers**

The host club may select a "tester" that they feel holds the characteristics needed as an evaluator for these tests. This person should be an agility instructor or experienced person within the sport that has excellent canine evaluation skills so that participants are being tested in a safe environment. The tester should be able to set up the test sequences or approve the course if setup by someone else. The tester shall sign all qualifying reports.

# **Beginners Agility - Level One**

## **Written segment - Level One – entry form**

1. The entrant must write their dog's registration number in a correct format. (tester must verify that the number format is correct)
2. Entrant must indicate how tall their dog is and in which height group their dog would belong into. The dog need not be measured at this level and the height can be estimated. (tester should be able to guesstimate the probable height group the dog would compete within)
3. The entrant must list the breed of their dog or indicate mixed breed. (tester must not accept any "made up" breeds and a mixed breed should not be listed by the "mix" of breeds, such as BC/Aussie. It should just say "mix breed" or All American, etc but no breed should be listed unless it is a purebred.
4. The entrant must write in a manner that is legible for the tester to read clearly.

## **Exercises – Level 1**

All exercises will be timed and all exercises will be allowed one retry if the first attempt is failed. The entrant must pass all tests to receive a qualifying score. The handler may have treats in a closed bag or pouch or pack, but they may not withdraw treats to give the dog until all tests are completed.

1. Start line – This exercise is to demonstrate the handler's basic off lead control at the start line. There shall be a box at the start that can be a minimum of 8' by 8' to a maximum of 10' by 10'. Once the tester has said "good luck" the handler shall remove the lead and the handler and dog shall stay in box for 5 seconds after leash is removed. If the dog leaves the box, the handler may call the dog back into the box and retry the exercise. If the handler must leave the box to catch the dog, the exercise is failed. The handler has 60 seconds to complete this exercise. This time includes the time for a retry on the exercise. The dog may move around the box during the 5 second count, as long as they do not leave the box area. The box may be marked by PVC poles, corner cones or survey tape or any other such item that clearly delineates the parameters of the box area.
2. In and Out gates – This exercise shall show the handler's ability to guide their dog through a three sided box using commands to move the dog out away from the handler and back in towards the handler. The handler may choose which direction they go, either clockwise or counter-clockwise. Once they have started the exercise, they must maintain their original direction of clockwise or counter-clockwise. At the first gate, the handler shall indicate to the dog to go to the outside of the gate while the handler remains to the inside. (order shall be handler-gate-dog). After the dog has passed the length of the gate, the handler shall call the dog to the inside of the box and the dog shall pass the second gate on the inside of the box (order shall be handler-dog-gate). The dog should not come to the side of the handler that puts the handler closer to the gate than the dog. The dog shall pass closest to the gate on the second gate. At the third gate, the handler shall again cue the dog to pass to the outside of the third gate, as they



did at gate #1. (order shall be handler-gate-dog). The handler shall remain on the inside of the three sided box at all times. If the handler must leave the box to get their dog back, then the exercise is failed. If the dog misses one of the gates the handler may restart the exercise. The dog and handler have 90 seconds to complete this exercise, including one restart.

3. Two gate Figure Eight – In this exercise the handler will demonstrate the handlers ability to work the dog off both sides. The handler shall start in the middle between two gates, with the dog on the handler's left side. The handler shall send the dog around the gate on the right in a clockwise direction. As the dog completes the right side gate, the handler shall change sides so that the dog is now working off the right side of the handler. The handler shall send the dog off their right side around the left gate in a counter-clockwise direction. The handler shall do this exercise in one continuous motion. The team may have one restart if they fail to maintain the correct handling side. The handler and dog have 90 seconds to complete this exercise, including one restart. The same gate setup may be used for this exercise, with the middle gate removed.
4. A frame – With this exercise, the handler shall show the dog's ability to safely go up and over the a-frame. The dog may walk or trot. A frame set at a height of three feet or lower, depending on the construction of the a-frame. The handler may assist the dog by patting the a-frame or petting the dog to encourage them. The handler will have 60 seconds to complete the a-frame, including one restart.
5. Hoops – two hoops in a row 10-12' apart. In this exercise, the handler will demonstrate their ability to send their dog in a forward direction to two obstacles. There shall be two hoops in a straight line and the handler shall send their dogs through those two hoops in a continuous forward motion. If the dog goes around a hoop, they can restart the exercise from the beginning one time. The handler may move parallel to the dog as they direct the dog through the two hoops. The handler may NOT lead out and call the dog through the hoops. If the dog leaves the plane of the width of the hoops as they progress from hoop #1 to hoop #2, they may restart the exercise one time. The handler and dog have 60 seconds to complete the test, including one restart.
6. Tunnel and Recall – In this exercise, the handler shall show the dog's ability to go through a tunnel and be recalled back to the handler. The handler must send their dog through the tunnel and then as the dog exits the tunnel they shall call the dog towards them. If the dog continues away from the handler after the handler has called the dog, then the tester may fail the team if the tester feels that the dog is refusing to return to the handler upon command. The handler may step to the side of the tunnel while the dog is within the tunnel or travel ½ way down the length of the tunnel if desired to keep the dog from going back through the tunnel in the opposite direction. If the dog does not immediately return to the handler or returns via the tunnel, the handler may restart the exercise. If the tester feels that the dog is not under control, then the tester might not allow a restart of the exercise. The handler and dog are allowed 60 seconds to complete the test, including one restart.
7. Walk with distraction – 15' walk on leash w/ distraction. In this exercise the handler shall demonstrate that they have control of their dog with a nearby distraction of another person and their dog. The "distracter" and their dog are to be inside an ex-pen area or other secured area. The distraction person may have a chair to sit in if desired. The

distraction person will interact quietly with their dog. Working dog must not approach distraction dog. The dog performing the test should not pull their handler on a leash towards the person and dog secured in the pen. The handler shall walk their dog approximately 15' past the distraction person and their dog. If the working dog tightens the leash towards the distractions, they may restart the exercise one time, unless the tester feels that the dog is not under control while near the distraction. The handler and dog have 60 seconds to complete the exercise, including one restart. The 15' area shall be delineated by cones in the four corners. The leash walker shall hand the leash to the handler at the start of the exercise. The dog being tested should not jump on the leash walker, nor growl or act aggressive or overly friendly in any way towards the leash walker.

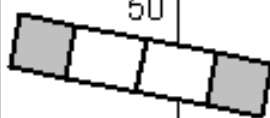
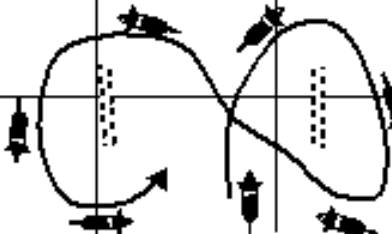

The handler is allowed to put the leash back on the dog in between exercises. If the handler already has their leash with them then the leash walker can just walk up to and past the dog and handler, on the handler's side of the team.

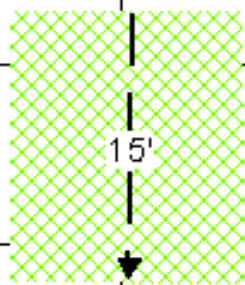
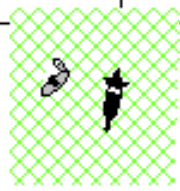
## Sample test setup for Beginners Agility – Level 1

<p>Note: The figure 8 test and the "In and Out" test can use the same gate setup and the tester can move the center gate in and out for the exercises.</p>					
10	20	30	40	50	70
70	2 Hoops			 A Frame	70
60				 Figure Eight	60
50	Tunnel and Recall			same gates can be used for tests 2 and 3	50
40				 In/Out Gates	40
30	Ex-pen area  15'				30
20	Walking exercise w/ Distractions				20
10		Leash walker		start line box	10
10	20	30	40	50	

**Sample test setup for Beginners Agility – Level 1 (long and narrow ring)**

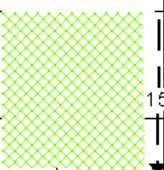
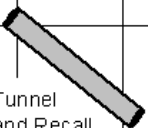
Note: The figure 8 test and the "In and Out" test can use the same gate setup and the tester can move the center gate in and out for the exercises.

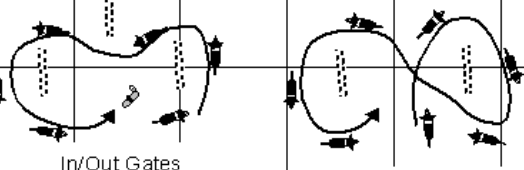
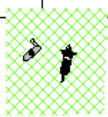
	10	20	30	40	50	
	140	Leash walker				140
	130					130
	120	Walking exercise w/ Distractions				120
	110					110
	100	Tunnel and Recall				100
	90					90
	80	2 Hoops				80
	70					70
	60	A Frame				60
	50					50
	40	In/Out Gates				40
	30			<p>Figure Eight They can use the same gates as the In and Out test</p>		30
	20	start line box				20
	10					10
	10	20	30	40	50	

**Rules**



All exercises are timed. The beginning of the time allowed will be indicated by the tester saying "good luck". The handler may have food and/or non-audible toys on them during the tests, although they may not be used during the tests.

Handlers may have up to 30 seconds between exercises to settle their dogs or praise them. The dogs should still remain under control of the handler and not run away or wander away sniffing between exercises.

The tester may end the test and not allow for any additional exercises to be performed if they feel that the dog is not under sufficient control of the handler.

All Beginners Agility tests shall start with test #1. The tests numbered #2-#5 can be in any order, as set by the designated tester. The BA test must end with tests #6 and #7, in that order.

## **Titles**

Once a dog has three qualifying rounds in Level 1 Beginners Agility, they will receive their BA-1 title. If two testers are available, then a club may allow for two test rounds per dog on the same day. If more than one test is being allowed on the same day, then each round must have a different tester. Each tester shall approve the course setup and may change the order of tests #2-#5.

If only one round is allowed per BA trial, then the club can use the same tester at each trial.

No more than two tests in a 48 hour period. So a club may have one test per day for two days, or they could have two tests in one day.

## **ADMINISTRATION**

Only NADAC Sanctioned Groups/Clubs may host a Beginners Agility Test.

Beginners Agility may be hosted as a stand alone event such as a class graduation test, or in conjunction with a regular NADAC trial.

An application to host a Beginners Agility Test is included with these guidelines.

The sanctioning fee is \$10.00 per class.

A sample entry form is included with these guidelines. This entry form may be included in the premium for pre-entry and is to be used as the written portion of Test 1 for Beginners Agility Level 1.

Sample Score Sheets are included with these guidelines.

The test score sheets are to be compiled and sent to NADAC. All sheets are to be signed by the Tester.

Testers are paid \$1.00 per dog, per class.

An Excel file summary of the dogs who pass is to be e-mailed to Sharon at [NADACSharon@aol.com](mailto:NADACSharon@aol.com) within 5 days post test.

This file should include the following:

- Date of Test
- Name of Host Club
- Tester's Name
- Dog's NADAC Registration Number
- Call Name
- Owner's First and Last Name
- A column indicating "Passed"

Recording fees in the amount of \$1.00 per dog, per class can be mailed to NADAC or paid via Paypal account [NADACSharon@aol.com](mailto:NADACSharon@aol.com)



# NORTH AMERICAN DOG AGILITY COUNCIL

## Beginners Agility Test Application Form

Please Type or Print Clearly *Incomplete or Illegible forms will be returned*

The class sanctioning fee is due with submission of application

Group/Club Name: \_\_\_\_\_

\*\*Week Number: \_\_\_\_\_ (please refer to the Calendar by Week # in the files section of the  
*Required* [www.nadacclubs@yahoo.com](mailto:www.nadacclubs@yahoo.com) list)

Date Requested: \_\_\_\_\_

Location of Test Site (City/State): \_\_\_\_\_

### Size of Actual Ring(s):

**Ring #1** width = \_\_\_\_\_ length = \_\_\_\_\_  
\_\_\_\_\_

**Ring #2** width = \_\_\_\_\_ length = \_\_\_\_\_  
\_\_\_\_\_

Test Area Surface: \_\_\_\_\_  
(specify: grass, dirt, sand, bark, matting, etc.)

Test Chair: \_\_\_\_\_  
Name E-Mail Address

Approved Tester #1: \_\_\_\_\_  
Name E-Mail Address

Approved Tester #2: \_\_\_\_\_  
(if applicable) Name E-Mail Address

The following to be listed on the NADAC web page Calendar of Events:

**Test Contact:** \_\_\_\_\_ **E-Mail:** \_\_\_\_\_

**Web Site:** \_\_\_\_\_

**Classes:**

Beginners Agility Level 1                      Round 1 [ ]                      Round 2 [ ]

Beginners Agility Level 2                      Round 1 [ ]                      Round 2 [ ]

Beginners Agility Level 3                      Round 1 [ ]                      Round 2 [ ]

Sanctioning Fees: # rounds \_\_\_\_\_                      \$10.00 per round                      \$ \_\_\_\_\_

Application may be submitted as an e-mail attachment to [NADACBecky@aol.com](mailto:NADACBecky@aol.com)

Fees may be paid on line via Paypal account [NADACSharon@aol.com](mailto:NADACSharon@aol.com) or mailed to:  
NADAC, P.O. Box 1206, Colbert, OK 74733

***The following Obstacles meet NADAC Specifications, are in Good Repair, and Available for this Test:***

**Equipment Available for Ring 1:**

- [ ] Material to delineate the parameters of the Start Line Box
- [ ] X-pen or other suitable secured area for Distraction Test
- [ ] 15' Tunnel
- [ ] Hoops (2 minimum)
- [ ] A-Frame (must be rubber covered)
- [ ] Gates (3 minimum)

**Equipment Available for Ring 2:**

- [ ] Material to delineate the parameters of the Start Line Box
- [ ] X-pen or other suitable secured area for Distraction Test
- [ ] Tunnel (15')
- [ ] Hoops (2 minimum)
- [ ] A-Frame (must be rubber covered)
- [ ] Gates (3 minimum)

**Comments:** \_\_\_\_\_

---

I certify that I have knowledge of, and are familiar with, and agree to abide by, the rules and Regulations of NADAC in effect at the time of this trial, and by any additional rules and regulations as approved by NADAC for this trial.

Signature of Test Chairperson: \_\_\_\_\_

Date: \_\_\_\_\_



NORTH AMERICAN DOG AGILITY COUNCIL

Beginners Agility Test

Written Segment – Entry Form

**NADAC Club Name**

Anywhere, USA, Canada, Australia

Date: \_\_\_\_\_

Owner's name: \_\_\_\_\_

**NADAC**

**Registration**

**Number:** \_\_\_\_\_

Dog's

Call Name: \_\_\_\_\_

Breed: \_\_\_\_\_

Birthdate: \_\_\_\_\_

Estimated Height at the withers: \_\_\_\_\_

Standard Division Jump Height:	8	12	16	20	20+
--------------------------------	---	----	----	----	-----

Class	Division	Level	Circle Day & Run
Beginners Agility	Standard	Level 1	Sat. Test 1 Sat. Test 2

**Entry Fees:** \$10.00 per round

\_\_\_\_\_

**Total Fees:** \_\_\_\_\_

In consideration of the acceptance of the entry, I/we certify that I/we have knowledge of, and are familiar with, and agree to abide by, the rules and Regulations of NADAC in effect at the time of this trial, and by any additional rules and regulations as approved by NADAC for this trial. I/we certify that the dog entered is not a hazard to persons or other dogs. **I/We further agree to be bound by the "Agreement" printed on the reverse side of this entry form.**

Signature: \_\_\_\_\_ Date: \_\_\_\_\_

Email address: \_\_\_\_\_

## **AGREEMENT**

The person who signs this agreement represents that he/she is authorized to enter into this agreement on behalf of both exhibitor and the owner of entered dog. In consideration of acceptance of this entry:

1.1 As used here NADAC means North American Dog Agility Council, its members, officers, directors, employees, show chairs, show committees and agents.

1.2 Exhibitor/owner, agree to abide by the rules and regulations of NADAC and any other rules and regulations appearing in the premium for this event.

1.3 Exhibitor/owner certify that the entered dog is not a hazard to persons, dogs or property and that the entered dog's rabies vaccination is current in accordance with the requirement of the state in which the dog resides.

1.4 Exhibitor/owner acknowledge all hazards presented by the event and the event premises, including but not limited to, the condition of the floors, stairways, halls, lighting, security measures or lack of, electrical appliances, fitting, show rings, parking areas and the presence of unfamiliar animals and people; exhibitor and owner assume the risk of any harm arising from these.

1.5 Exhibitor/owner release NADAC (Including NADAC officers directors, employees and members), and will defend them and hold them harmless from all present and future loss, injury, damage, claims, demands and liabilities involving the entered dog, the event or event premises. Without limiting the generality of the foregoing hold harmless provisions, exhibitor/owner hereby specifically assume sole responsibility for and agree to indemnify and save aforementioned parties harmless from any and all loss and expenses (including legal fees) by reason of the liability imposed by law upon any of the aforementioned parties for damages because of bodily injuries, including death, at any time in consequence of my (our) participation in this event, howsoever such injury or death may be caused and whether or not the same may have been caused or may have been alleged to have been caused by negligence of the aforementioned parties or any of their employees or agents or any other persons.



**NORTH AMERICAN DOG AGILITY COUNCIL**

**BEGINNERS AGILITY TEST SCORESHEET**

DATE: \_\_\_\_\_ HOST CLUB/GROUP: \_\_\_\_\_

LOCATION: \_\_\_\_\_

DOG'S CALL NAME: \_\_\_\_\_ REG. # \_\_\_\_\_

**LEVEL 1** [ ]

**LEVEL 2** [ ]

**LEVEL 3** [ ]

<b>Test</b>	<b>PASS</b>	<b>FAIL</b>	<b>COMMENTS</b>
Written Segment			
Start Line Stay			
In and Out Gates			
Two Gate Figure Eight			
A-Frame			
Hoops			
Tunnel and Recall			
Walk with Distraction			

Tester's Signature: \_\_\_\_\_